



#### Product Summary

$V_{(BR)DSS}$	$R_{DS(on)TYP}$	$I_D$
40V	17mΩ@10V	18A
	23mΩ@4.5V	
-40V	42mΩ@-10V	-17A
	70mΩ@-4.5V	

#### Feature

- Trench Technology Power MOSFET
- Low  $R_{DS(ON)}$
- Low Gate Charge
- Low Gate Resistance

#### Application

- PWM Applications
- Load Switch
- Power Management

#### MARKING:

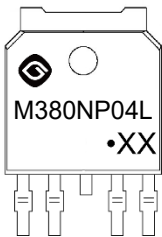

M380NP04L = Device Code  
 XX = Data Code  
 Solid Dot = Green Device Indicator

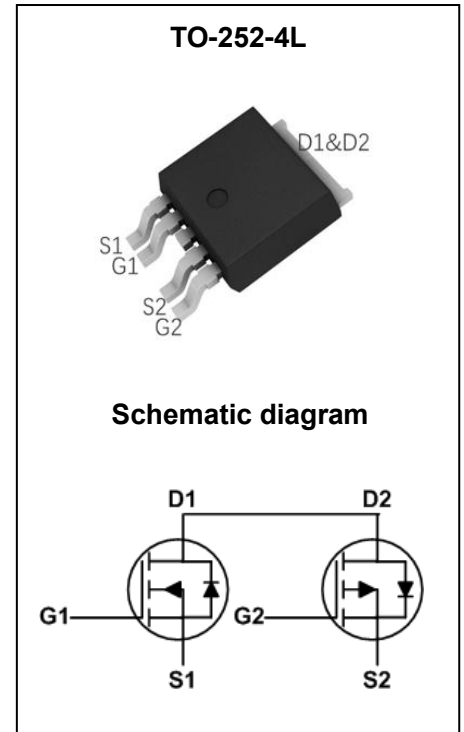

#### ABSOLUTE MAXIMUM RATINGS ( $T_A = 25^\circ\text{C}$ unless otherwise noted)

Parameter	Symbol	NMOS	PMOS	Unit
Drain - Source Voltage	$V_{DS}$	40	-40	V
Gate - Source Voltage	$V_{GS}$	$\pm 20$	$\pm 20$	V
Continuous Drain Current <sup>1</sup>	$I_D$	18	-17	A
Pulsed Drain Current <sup>2</sup>				
Single Pulsed Avalanche Current <sup>3,4</sup>	$I_{AS}$	10	-12	A
Single Pulsed Avalanche Energy <sup>3,4</sup>	$E_{AS}$	25	36	mJ
Power Dissipation <sup>6</sup>	$P_D$	41.5	41.5	W
Thermal Resistance from Junction to Ambient <sup>7</sup>	$R_{\theta JA}$	60	60	$^\circ\text{C/W}$
Thermal Resistance from Junction to Case	$R_{\theta JC}$	5.5	5	$^\circ\text{C/W}$
Junction Temperature	$T_J$	150	150	$^\circ\text{C}$
Storage Temperature	$T_{STG}$	-55~ +150	-55~ +150	$^\circ\text{C}$

## MOSFET ELECTRICAL CHARACTERISTICS ( $T_A = 25^\circ\text{C}$ unless otherwise noted)

### NMOS:

Parameter	Symbol	Test Condition	Min	Type	Max	Unit
<b>Off Characteristics</b>						
Drain - Source Breakdown Voltage	$V_{(BR)DSS}$	$V_{GS} = 0V, I_D = 250\mu A$	40			V
Zero Gate Voltage Drain Current	$I_{DSS}$	$V_{DS} = 40V, V_{GS} = 0V$			1	$\mu A$
Gate - Body Leakage Current	$I_{GSS}$	$V_{GS} = \pm 20V, V_{DS} = 0V$			$\pm 100$	nA
<b>On Characteristics<sup>3</sup></b>						
Gate Threshold Voltage	$V_{GS(th)}$	$V_{DS} = V_{GS}, I_D = 250\mu A$	1.0	1.7	3.0	V
Drain-source On-resistance	$R_{DS(on)}$	$V_{GS} = 10V, I_D = 6A$		17	26	m $\Omega$
		$V_{GS} = 4.5V, I_D = 6A$		23	39	
<b>Dynamic Characteristics</b>						
Input Capacitance	$C_{iss}$	$V_{DS} = 20V, V_{GS} = 0V, f = 1MHz$		702		pF
Output Capacitance	$C_{oss}$			59		
Reverse Transfer Capacitance	$C_{rss}$			48		
Gate Resistance	$R_g$	$V_{DS} = 0V, V_{GS} = 0V, f = 1MHz$		3.6		$\Omega$
<b>Switching Characteristics</b>						
Total Gate Charge	$Q_g$	$V_{DS} = 20V, V_{GS} = 10V, I_D = 6A$		20		nC
Gate-source Charge	$Q_{gs}$			2.8		
Gate-drain Charge	$Q_{gd}$			6		
Turn-on Delay Time	$t_{d(on)}$	$V_{DD} = 20V, V_{GS} = 10V, R_G = 2.5\Omega, R_G = 3\Omega$		5		ns
Turn-on Rise Time	$t_r$			3		
Turn-off Delay Time	$t_{d(off)}$			15		
Turn-off Fall Time	$t_f$			2		
<b>Source - Drain Diode Characteristics</b>						
Diode Forward Voltage <sup>3</sup>	$V_{SD}$	$V_{GS} = 0V, I_S = 1A$			1.2	V

## PMOS:

Parameter	Symbol	Test Condition	Min	Type	Max	Unit
<b>Off Characteristics</b>						
Drain - Source Breakdown Voltage	$V_{(BR)DSS}$	$V_{GS} = 0V, I_D = -250\mu A$	-40			V
Zero Gate Voltage Drain Current	$I_{DSS}$	$V_{DS} = -40V, V_{GS} = 0V$			-1	$\mu A$
Gate - Body Leakage Current	$I_{GSS}$	$V_{GS} = \pm 20V, V_{DS} = 0V$			$\pm 100$	nA
<b>On Characteristics<sup>3</sup></b>						
Gate Threshold Voltage	$V_{GS(th)}$	$V_{DS} = V_{GS}, I_D = -250\mu A$	-1.0	-2.1	-3.0	V
Drain-source On-resistance	$R_{DS(on)}$	$V_{GS} = -10V, I_D = -5A$		42	55	m $\Omega$
		$V_{GS} = -4.5V, I_D = -5A$		70	86	
<b>Dynamic Characteristics</b>						
Input Capacitance	$C_{iss}$	$V_{DS} = -20V, V_{GS} = 0V, f = 1MHz$		671		pF
Output Capacitance	$C_{oss}$			67		
Reverse Transfer Capacitance	$C_{rss}$			51		
Gate Resistance	$R_g$	$V_{DS} = 0V, V_{GS} = 0V, f = 1MHz$		24		$\Omega$
<b>Switching Characteristics</b>						
Total Gate Charge	$Q_g$	$V_{DS} = -20V, V_{GS} = -10V, I_D = -5A$		18.4		pC
Gate-source Charge	$Q_{gs}$			3.1		
Gate-drain Charge	$Q_{gd}$			5.6		
Turn-on Delay Time	$t_{d(on)}$	$V_{DD} = -20V, V_{GS} = -10V,$ $R_G = 2.3\Omega, R_G = 6\Omega$		8		ns
Turn-on Rise Time	$t_r$			6		
Turn-off Delay Time	$t_{d(off)}$			20		
Turn-off Fall Time	$t_f$			7		
<b>Source - Drain Diode Characteristics</b>						
Diode Forward Voltage <sup>3</sup>	$V_{SD}$	$V_{GS} = 0V, I_S = -1A$			-1.2	V

### Notes :

- 1.The maximum current rating is limited by package.And device mounted on a large heatsink
- 2.Pulse Test : Pulse Width  $\leq 10\mu s$ , duty cycle  $\leq 1\%$ .
- 3.EAS condition:  $V_{DD} = 20V, V_{GS} = 10V, L = 0.5mH, R_G = 25\Omega$  Starting  $T_J = 25^\circ C$ .
- 4.EAS condition:  $V_{DD} = -20V, V_{GS} = -10V, L = 0.5mH, R_G = 25\Omega$  Starting  $T_J = 25^\circ C$ .
- 5.Pulse Test : Pulse Width  $\leq 300\mu s$ , duty cycle  $\leq 2\%$ .
- 6.The power dissipation  $P_D$  is limited by  $T_{J(MAX)} = 150^\circ C$ .And device mounted on a large heatsink
- 7.Device mounted on  $1in^2$  FR-4 board with 2oz. Copper, in a still air environment with  $T_A = 25^\circ C$ .

**Typical Characteristics**

**NMOS:**

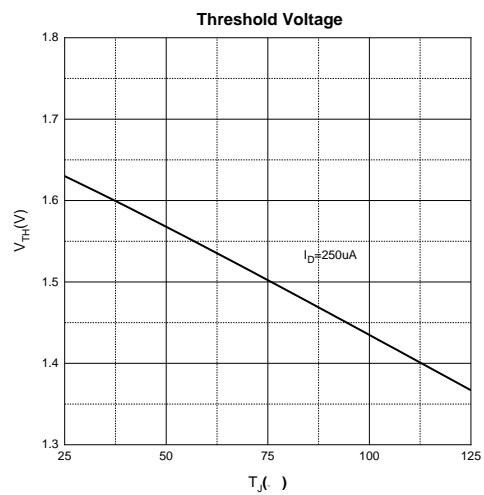
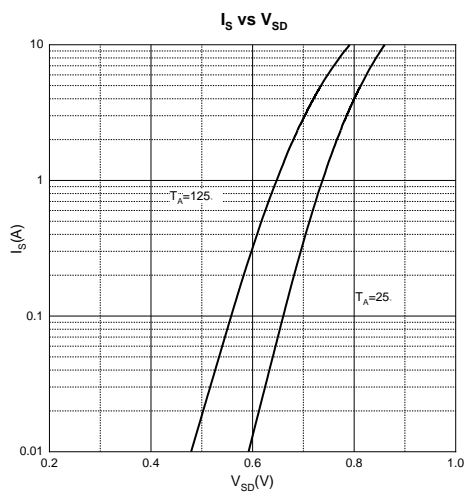
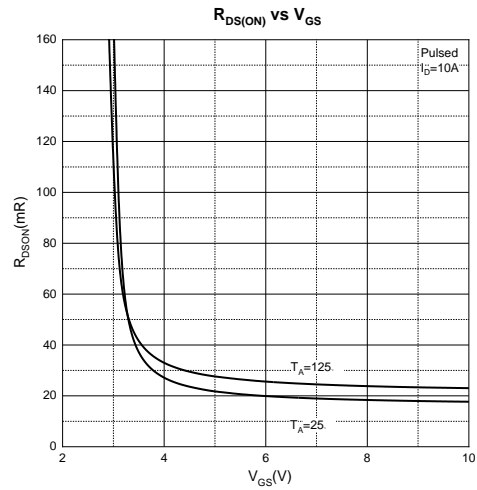
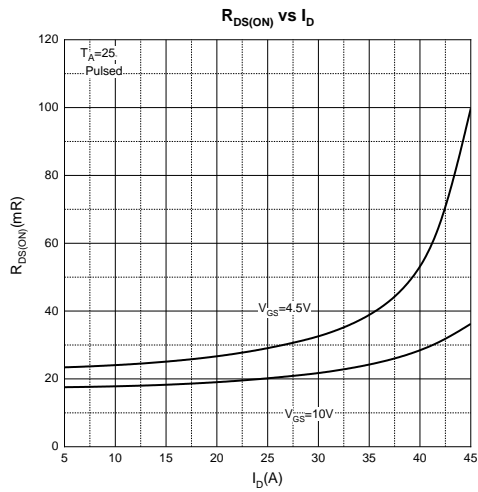
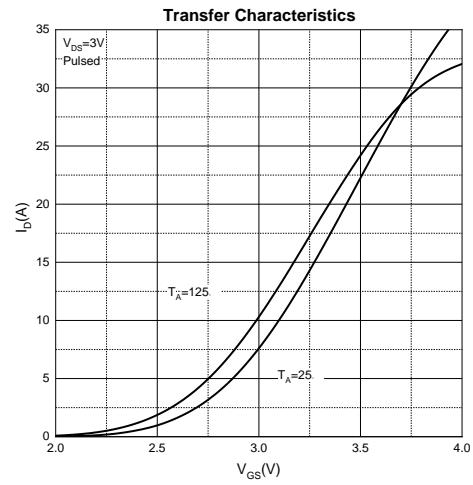
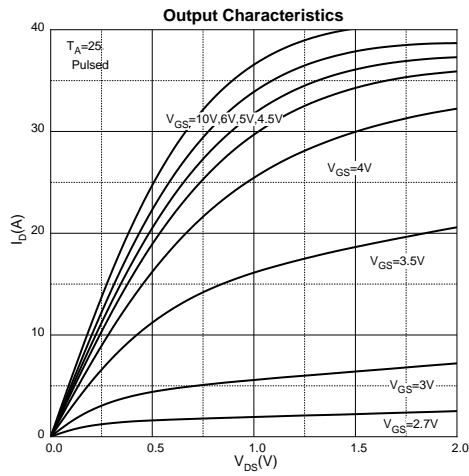

**PMOS:**

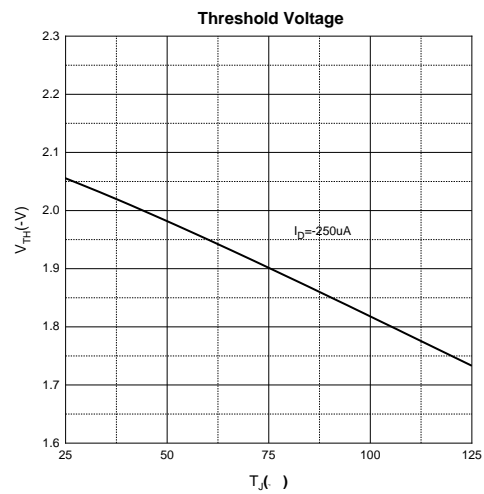
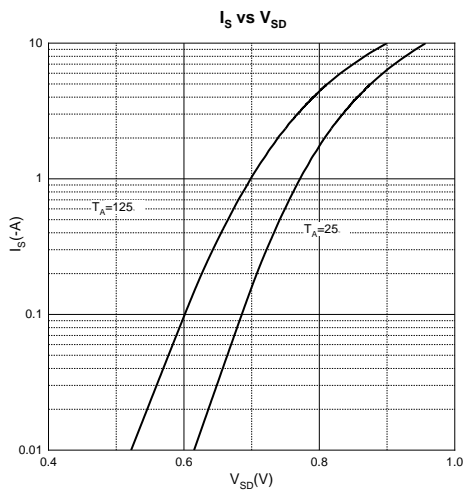
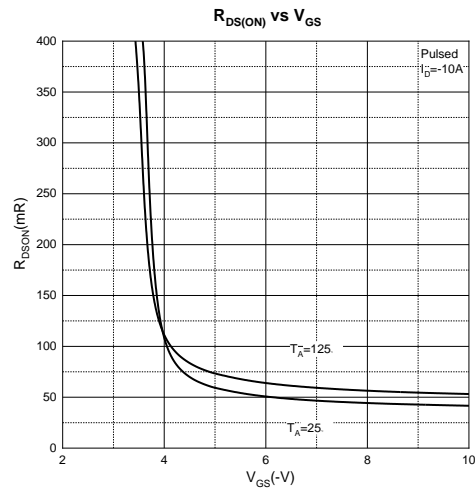
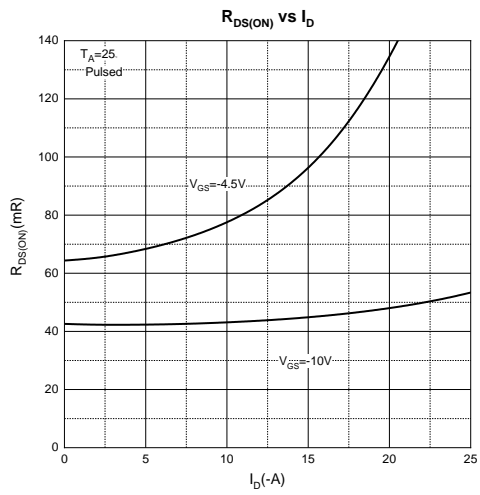
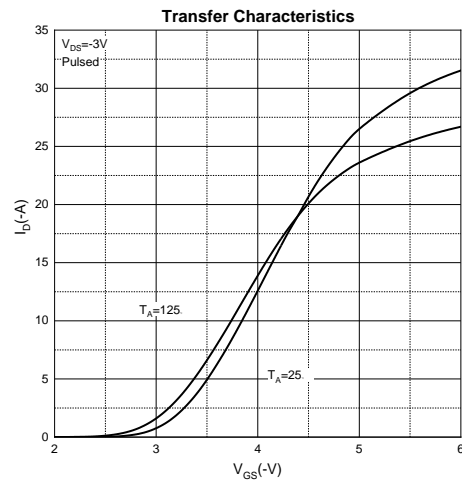
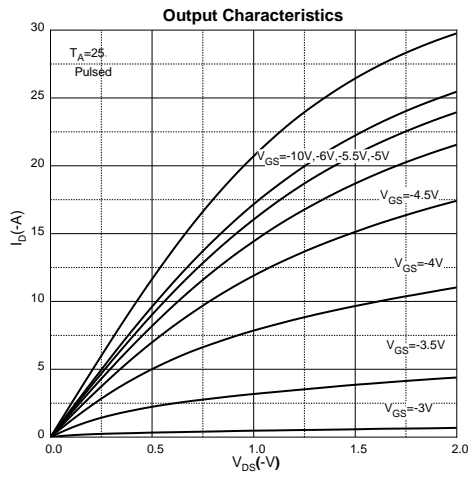

## TO-252-4L Package Information

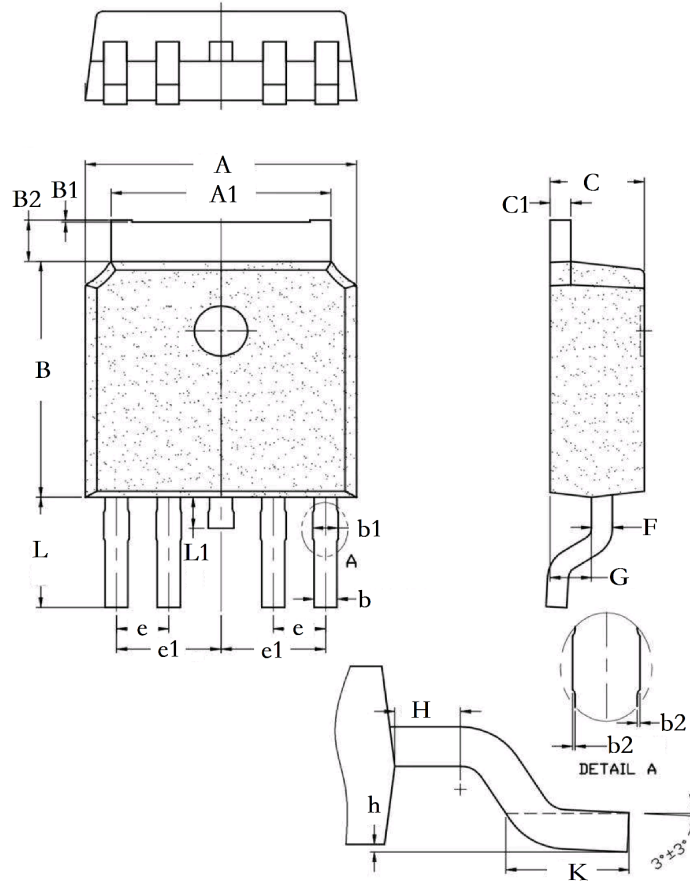

Symbol	Dimensions In Millimeters		Dimensions In Inches	
	Min.	Max.	Min.	Max.
A	6.550	6.650	0.258	0.262
A1	5.234	5.434	0.206	0.214
B	6.050	6.150	0.238	0.242
B1	0.000	0.050	0.000	0.002
B2	0.962	1.162	0.038	0.046
C	2.250	2.350	0.089	0.093
C1	0.458	0.558	0.018	0.022
L	2.698	2.998	0.106	0.118
L1	0.700	0.900	0.028	0.035
b	0.510	0.610	0.020	0.024
b1	0.570	0.670	0.022	0.026
b2	0.000	0.050	0.000	0.002
e	1.270TYP		0.050TYP	
e1	2.540TYP		0.100TYP	
F	0.458	0.558	0.018	0.022
G	0.960	1.06	0.038	0.042
H	0.650	0.950	0.026	0.037
h	0.050	0.150	0.002	0.006
K	1.300	1.700	0.051	0.067

**Attention:**

- GreenPower Electronics reserves the right to improve product design function and reliability without notice.
- Any and all semiconductor products have certain probability to fail or malfunction, which may result in personal injury, death or property damage. Customer are solely responsible for providing adequate safe measures when design their systems.
- GreenPower Electronics products belong to consumer electronics or other civilian electronic products.